



PERFORMANCE ANALYSIS OF HARD DISK DRIVES AND IMPROVEMENT OF STORAGE DRIVES CAPACITY USING NAND SOLID STATE DEVICE (SSD) DRIVES IN COMPUTING

¹Tawo, Godwin A, ¹Fischer Gertrude A, ¹Antigha A E ¹Utsu Mathias M, ¹Ogar, Jerry E. ¹Etim Bassey E

¹Electronic & Communication Engineering, Department of Electrical/Electronic Engineering, Faculty of Engineering, University of Cross River Calabar Nigeria.

Corresponding authors: godwintawo@unicross.edu.ng

Abstract

This paper delved on computer components replacement and evaluation of the efficiency of Hard Disk Drives; (SATA and SSD storage drives). During this research activity we observed that NAND SSD storage drives have valuable parameters in terms of smartness as well as improvement in the storage performance, scalable and is durable because it does not have read/write heads and rotating mechanisms that wear-off due to corrosion and fatigue of the mechanical components. Figures 5, and 6, deduced their failure rate. The operating capacity and functionality of the Hard Disk Drives decrease with time and in most periods it involved complete replacement of the entire component. The overall efficiency of NAND SSD device also observed in the evaluations are smartness in terms of memory space location, easily accessible in data operation, the device possesses a higher reliability, is driven by multiple processors and portable, since it did not operate as a mechanism device, it has low power consumption due to gate families' characteristics of 5V usage, which is in line with perceived observations from performance determination. From the analysis Hard Disk Drives efficiency over seven years, are found to perform below average but at maximum percent of usage the upgraded component should be obsolete which is an evident for replacement, It can also be deduced that more than 53.2 percent of Hard Disk Drives on an average should be updated in a given interval, maximum duration is ten years, due to this limitations, NAND SSD drives technology play a significant role in durability, access to files and folders are made faster and possible. Control panel and processing components increases speed of access to data, bus control applications have highly improved using SSD and since they is no platter, sector and track mechanism. Cache controller and reliability is assured with SSD and self-monitoring analysis and reporting technology (SMART) have improved, which is a passive measured on troubleshooting. Since computer components decreases performance due to usage.

Keywords: NAND SSD, HDD, IDE, SATA Configuration, SMAR

1.0 Introduction

Storage components have improved with new technologies in computing called SSD, Solid State Device (SSD) drives are replacing Hard Disk Drives like IDE and SATA technologies due to mechanical component parameters (actuator motors, read/write heads and disc platter), form factors and design structure of Drives. Which were some major challenges with IDE and SATA drives, with innovations in technology previously IDE were replaced with SATA, owing to the fact that IDE also suffered some setbacks from configuring Slave and Master and others issues that link to compatibility. And now SATA are replaced with SSD. The versatility of the new drive has improved on scalability and duration storage capacity of data.

The technology of SMART centered on IDE and SATA drives. SSD drives has completely improved, ameliorated, jittering, Latencies and temperature acclimation which are an attributes of SATA and IDE. SSDs are very stable storage devices insuring that stored data is secure in the advent of failure. SATA drives were only able to achieve 50-120 MB/s in write performance. In comparison, SSDs saturate the SATA bus at 550 MB/s and superior data transfer speed is the most dramatic

difference between SSDs and SATA, time spent loading operating system. SSDs consume significantly less power than SATA and IDE drives, which have significant improvement in power consumption and are used for long-term backups and speed-driven applications [1, 11]

As the demand for complex computation with exponential higher speed, the SSDs are becoming prevalent storage drives. These storage devices have potentials to replace traditional HDDs not only because they are faster but also they have improved in their design and structure. The primary concern for SSD is its reliability, and how they perform over time [1], NAND flash based Solid State Drive (SSD) are sought to be an alternative to reduce the I/O bottleneck . The work of CRC and uncorrectable error count and finally SATA downshifting count.

According [2] explain how loss of data process is only triggered by the Terrain Resource Information Management (TRIM) command, and the data losses itself is carried out by the separate process of background garbage collection. The authors also explain how different outcomes are found as at when TRIM is operating. In some cases, they found all zeros, and in

other times they find actual data. Because some drives implement Deterministic Read after TRIM (DRAT) and some Deterministic Zeroes after TRIM (DZAT)

In [10] it enables the operating system to notify the SSD drive that, old data are no longer valid and is appropriate to deletes the logical block addresses from its logical table. The advantage of the TRIM command is that it enables the SSD's garbage collection to skip the invalid data rather than

moving it, thus saving time not rewriting the invalid data. This results in a reduction of the number of erase cycles on the flash memory and enables higher performance during writes.

1. SATA and SSD components structure

System components shows similar indicators when it needs an update and those indicators can appear in any component of the system.

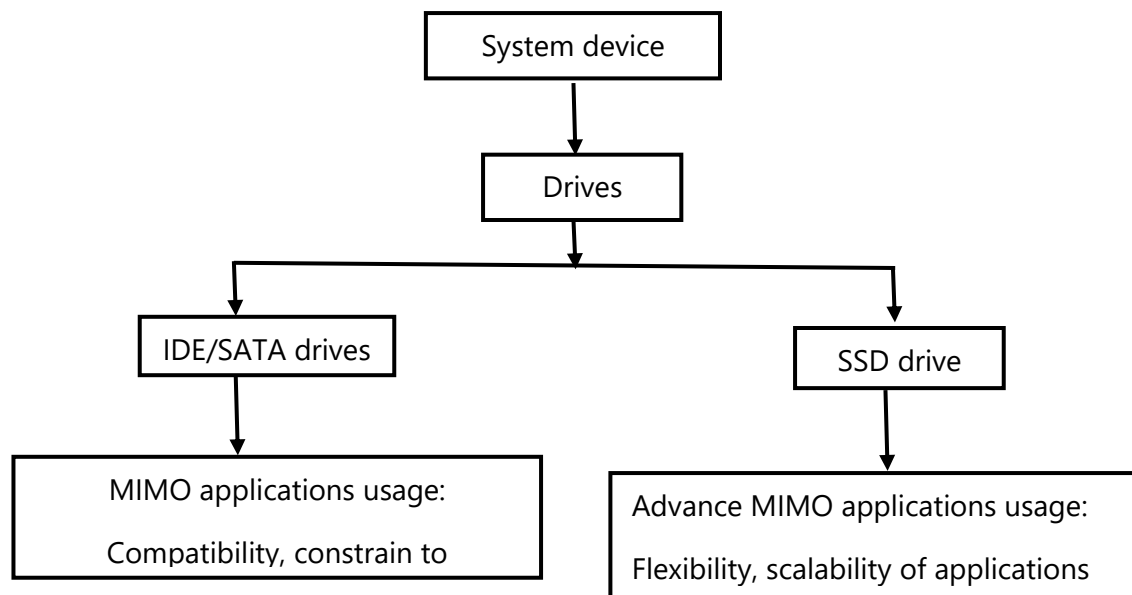

Figure. 1. SATA and SSD structure

The work of [3]. Which identify three key aspects of drive values that are of particular relevance to organizational information systems. The first of these is the utility that a drive offers to an organization. The second is the shortcomings in the functional

capabilities of a drive that impose constraints on the value that it can offer. The third key aspect of value that is identify is the reliability of a drive. While nonfunctional in nature, the value that even a highly useful drive with very few

functional limitations will deliver can be unreliable with multiple applications (advance-MIMO) shown in figure 1.

In [4] while prior work suggests that organizations will prefer to upgrade information of drives when they are useful, it is possible for a computer system device to be deemed useful while nonetheless suffering from notable limitations in its functional capabilities. These limitations constrain the potential value that a system is capable of offering and will, as such, undermine managerial enthusiasm for undertaking system upgrades. In addition, as shortcomings in the capabilities of a system become increasingly evident, users can become frustrated. This can lead them to devise other approaches to completing required tasks and to stop using the frustrating system to perform discretionary tasks [5].

According to [6] said that organizational information drives that are unable to evolve in response to changing organizational needs and circumstances are at considerable risk of becoming both technically and functionally obsolete. At such, IS managers can be expected to consider the capacity of an existing system to change and improve as needed when making an IS end-of life decision. A drive that is constrained in this

severely constrained when the hard drive is regard will typically be targeted for replacement to minimize organizational dependence on a system that may prove to be both costly and difficult to change. Prior work suggests three key aspects of organizational information systems that underlie their capacity for evolution. The first two are the ready availability of system support and the costs of obtaining this support.

The third is the extent to which a system has been altered or customized to align with the needs of a specific organization. Such customizations can notably impede the maintenance and enhancement efforts that drive system evolution. All computer systems runs on a specific storage device called as disk drives. These are of various types, IDE SATA and solid state drives. They are responsible to store data on it. Primary work shows that recent type of storage drive behaves in a different manner than existing hard drive technology where we are using a magnetic tape, and presents unique challenges with respect to data retention and forensic investigation A Solid-State Drive (SSD) sometimes referred to as an SSD flash drive, is made from semiconductor components known as “NAND flash”. NAND flash is rewriteable

non-volatile semiconductor memory. A flash device in a single monolithic package called a flash chip. Several flash chips are mounted Client applications are also in need of an alternative to electromechanical disk drives that can deliver faster response times, use less power, and fit into smaller mobile form factors. Flash-memory-based SSDs can offer much faster random access to data and faster transfer rates. Moreover, SSD's capacity is now at the point where solid state is used for storing data before their transfer to the Flash. The benefit is that data updating, e.g.

onto a printed circuit board (PCB) inside the SSD to create large storage capacities [9].

of routing tables, is faster and does not wear out the Flash. A typical memory system is composed of several NAND memories [1]. Typically, an 8-bit bus [2, 3], usually called “channel”, is used to connect different memories to the controller (Figure 2). It is important to underline that multiple Flash memories in a system are both a means for increasing storage density and read/write performances

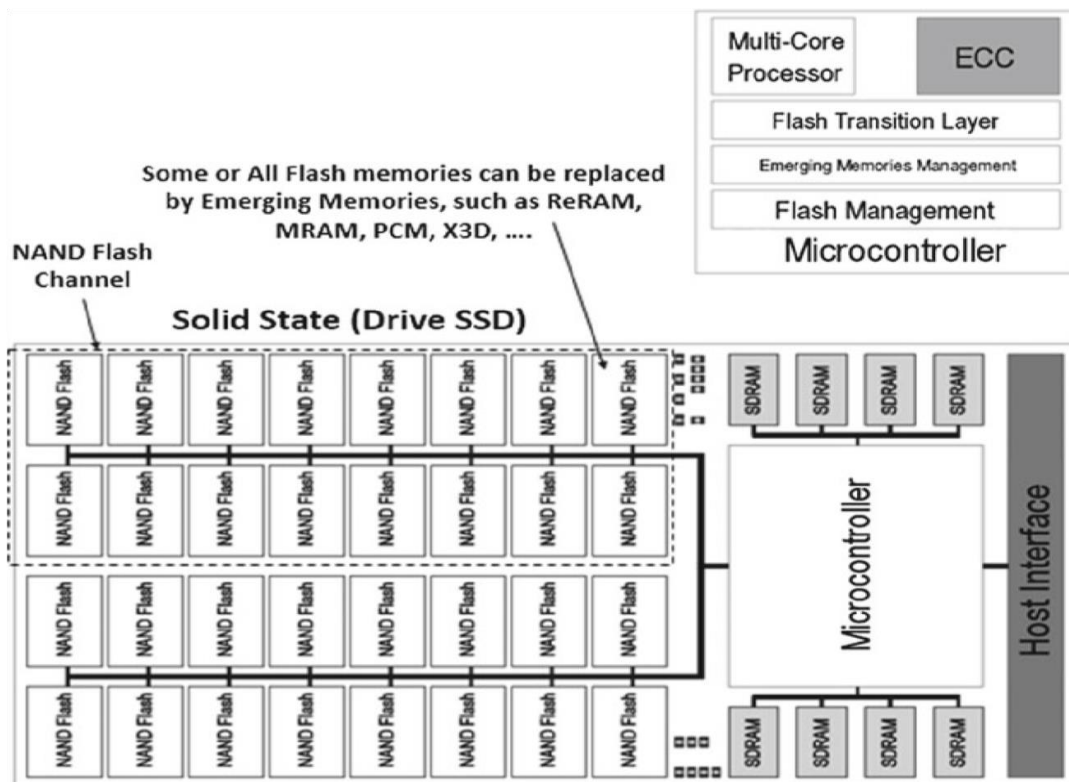

Figure 2, Block diagram of SSD [12]

2. SSD structure and performance

The performance of SSDs differs significantly from HDDs due to the unique attributes of NAND flash based SSD architecture. Unlike SATAs, SSDs have distinct performance states. As a result, SSD performance:

- Changes over time;
- Depends on the write history of the SSD
- Depends on the type of stimulus being applied to the drive.

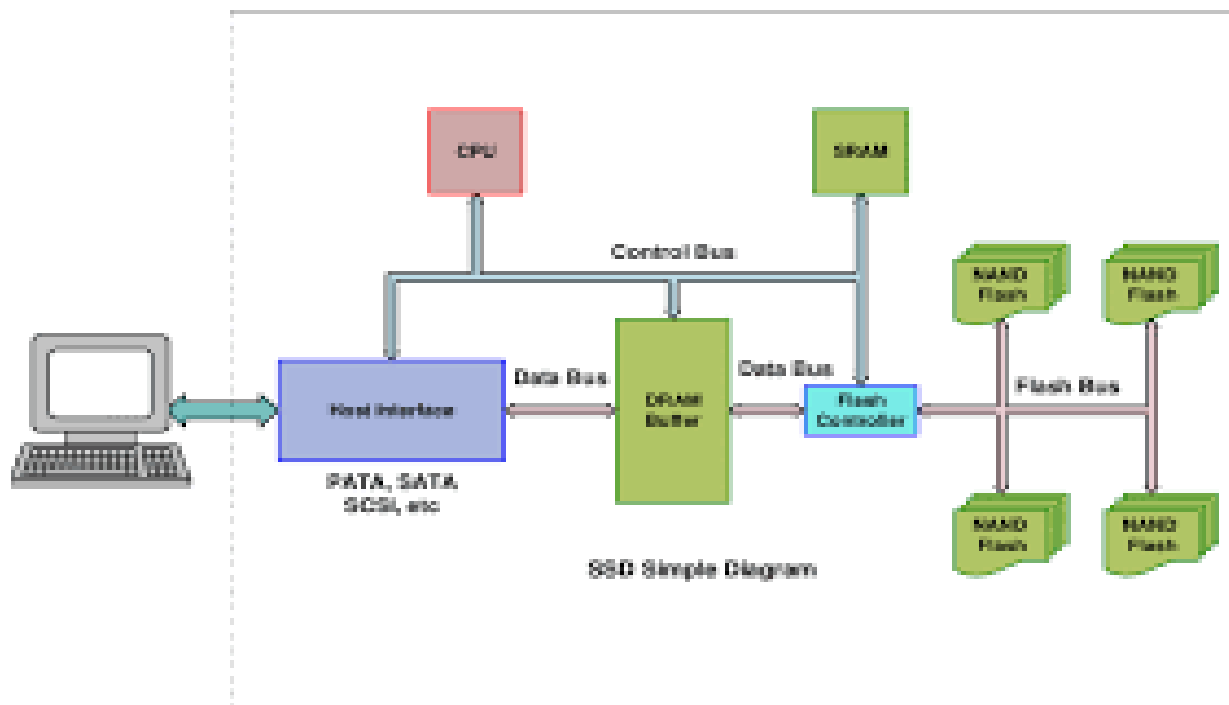

Figure 3. Block diagram of SSD [3]

The key components of Solid State Drives (SSD) as seen in figure 3: are the controller and the memory used to store the data. The primary memory component in an SSD had been Dynamic Random Access Memory (DRAM) is a volatile memory since they were first developed in 2009. Now it is commonly NAND flash non-volatile

memory which had been introduced recently.

Performance measurements are highest when the SSD is brand new and has no write history.

SSD performance will settle over time to a lower, more stable range (known as Steady State – a specifically defined as Performance

Test Specification (PTS) region where performance response is relatively time invariant.

3. Performance analysis of Hard disk drives (HDD)

'A' in the course of a given time interval. HPM was adapted to hard disk drives to study the component over some duration of their operating conditions, the event 'A' may be a need for an upgrade process. The following conditions are assumed to be fulfilled:

1. The event 'A' may occur at any time in the interval, and the probability of 'A' occurring in the interval $(t, t + \Delta t)$ is independent of t and may be written as $\lambda \cdot \Delta t + o(\Delta t)$, where λ is a positive constant.
2. The probability of more than one event 'A' in the interval $(t, t + \Delta t)$ is $o(\Delta t)$
3. Let $(t_{11}, t_{12}), (t_{21}, t_{22}) \dots$ be any sequence of disjoint intervals in the time period in operation. Then the

$$P_r(N(t)) = n = \frac{(\lambda t)^n}{n!} e^{-\lambda t} \text{ for } n = 0, 1, 2, \dots \quad (3.1)$$

The distribution (3.1) is called the Poisson distribution. When we observe the occurrence of events of 'A' in an interval $(s, s + t)$ the probability that 'A' occurs exactly n Times in $(s, s + t)$ is: $P_r(N(S + 1)) - N(S) = N = \frac{(\lambda t)^n}{n!} e^{-\lambda t} \text{ for } n = 0, 1, 2, \dots \quad (3.2)$

That is, the same event as is found in equation (3. 1). The important quantity is therefore the length 't' of the time interval we are observing the process, not when this interval starts.

Introducing the homogeneous Poisson Method (HPM) which is an expression used in describing the occurrence of an event in a system,. The HPM is used to model occurrences of a specific event events 'A' occurs in (t_{j1}, t_{j2}) , $j = 1, 2, \dots$ are independent.

Without loss of generality we let $t = 0$ be the starting point of the process.

Let $N(t)$ denote the number of times the event 'A' occurs during the interval $(0, t)$.

The stochastic method $(N(t), t \geq 0)$ is then an HPM with rate n . The rate ' λ ' be the frequency of events 'A', An out-come of assumption 1 is that the rate of events 'A' is constant, and does not change with time. The time, 't' measured as calendar time or operational time. In many cases several components are running in parallel and the time 't' must then be measured as total or accumulated time in service. Suited for cases when we observe failures in a population of replaceable items. An event 'A' occurs exactly n times in the time interval $(0, t)$ is:

The mean number of events for device replaced in $(0, t)$ is:

$$E(N(t)) = \sum_{n=0}^{\infty} n \cdot P_r(N(t) = n) = \lambda t \tag{3.3}$$

And the variance is given as

$$\text{var}(N(t)) = \lambda t \tag{3.4}$$

From equation (3.3), the parameter λ may be written as $\lambda = N(t) / t$, that is, the Mean number of replaceable devices per time unit. This is why λ is called the rate of the HPM. When the event ‘A’ is a replacement λ is the ROCOR of the HPM, a natural unbiased estimator of λ is expressed as:

$$\lambda = \frac{N(t)}{t} = \frac{\text{Number of events replacement in an interval of time duration } t}{\text{Duration } t \text{ of the interval}} \tag{3.5}$$

Let T_1 denote the time when ‘A’ occurs for the first time, and let $F_{T_1}(t)$ denote the distribution function of T_1 . Since the event $T_1 > t$ means that no event has occurred

In the interval $(0, t)$. we get:

$$F_{T_1}(t) = P_r(T_1 \leq t) = 1 - P_r(T_1 > T) \tag{3.6}$$

$$= 1 - P_r(N(N(t)) = 1 - e^{-\lambda t} \quad \text{for } t \geq 0 \tag{3.7}$$

The time T_1 to the upgrade component device A is seen to be exponentially distributed with parameter λ . That the times between events, T_1, T_2, \dots are independent, and exponentially distributed with parameter λ . The times between events T_1, T_2, \dots are called the inter-occurrence times of the process of replacement.

Consider a component that is in operation at time $t = 0$. The first failure (replacement A) occurs at time T_1 . When the component has failed, it should be replaced with a new component of the same type. The

replacement time should be short so that it can be neglected. The second failure occurs at time T_2 , and so on. We thus get a sequence of times T_1, T_2, \dots the number of devices experiencing failures $N(t)$ in the time interval $(0, t)$ is assumed to be Poisson distributed with $(\text{ROCOR})\lambda$. The inter-occurrence times T_1, T_2, \dots are then independent and exponentially distributed with replacement rate A. Note the important difference between the concepts “replacement rate” and ROCOR. Let us consider an HPM with rate λ , and assume

that we are interested in determining the distribution of the time S_k where A occurs for the kth time (k is accordingly an integer). We let t be an arbitrarily chosen point of

time on the positive real axis. The event ($T_k > t$) is then obviously synonymous with the upgrade that 'A' is done at most (k - 1) times in the time interval (0, t). Therefore

$$P_r(S_k > t) = P_r(N(t) \leq k - 1) = \sum_{j=0}^{k-1} \frac{(\lambda t)^j}{j!} e^{-\lambda t} \quad (3.8)$$

Where $F_{St}(t)$ is the distribution function of a component for S_k . The probability density function $F_{St}(t)$ is obtained by differentiating $F_{St}(t)$ with respect to t:

$$F_{St}(t) = \frac{\lambda}{k-1} (\lambda t)^{k-1} e^{-\lambda t} \quad \text{for } t \geq 0 \text{ and } \lambda > 0 \quad (3.9)$$

Where k is a positive integer. This distribution is called the replacement system distribution with parameters k and A. It can therefore be concluded that the waiting time until the kth occurrence of A in an HPM with rate λ is gamma distributed (k, A). If a component say SATA drive has a need for replacement with a total work rate of A. = 4.28 *10exp (-4). Hours' (data from

UNICROSS 2024). With an estimate that the component has stay and function for a period of (f = 6 hours) in continuous operation which need a replacement as: meaning components have failure rate.

$$A(t) = e^{-\lambda t} = e^{-4.28 \times 10^{-4} \times 6} \approx 0.732.$$

The result means that Hard Disk drives need replacement after a long duration of service as determined in table 1.

Table 1. Operating condition of HDD over (7) year periods

Operation Time (hrs.)	Year 1 2018	Year 2 2019	Year 3 2020	Year 4 2021	Year 5 2022	Year6 2023	Year 7 2024
0	1.000	1.0000	1.0000	1.000	1.0000	1.0000	1.0000
1	0.3679	0.1353	0.0498	0.0183	0.0067	0.0025	0.0009
2	0.1353	0.0183	0.0025	0.0003	0.0000	0.0000	0.0000

3	0.0498	0.0025	0.0001	0.0000	0.0000	0.0000	0.0000
4	0.0183	0.0003	0.0000	0.0000	0.0000	0.0000	0.000
5	0.0067	0.0000	0.0000	0.0000	0.0000	0.0000	0.000
6	0.0025	0.0000	0.0000	0.0000	0.0000	0.0000	0.000
7	0.0009	0.0000	0.000	0.0000	0.0000	0.000	0.000

Comparison of drives; SATA and SDD in term of operation and functionality, we observed that SSD performance and its efficiency is perfect. As seen in table 2. storage technology. SATAs are read/write mechanical devices with moving parts that store data on a magnetic rotating platter. They use a complex arrangement of motor-driven spindles, actuator arms and other mechanical parts to position a recording head over the rapidly spinning m SSDs (consisting primarily of the Controller and Flash Memory) are ‘solid’ or ‘static.’ Data can be stored in a permanent state when the power supply is removed. Because there are

Hard disk drives were first introduced by IBM in 1956. They have improved continuously since and remain a dominant data

no moving parts combined with the differences in memory types (RAM is used in solid state technology while SATA use sequential processing), SSDs support read/write data functions at much higher IOPS (Input-Output per Second) speeds than SATAs. Prior to the development and successful deployment of NAND Flash non-volatile memory, [7] DRAM volatile memory was widely used to store data in SSDs and their comparison seen in table 2.

Table 2. Comparison chart for SATA and SSD

S/N	COMPARISON CHART	SSD	SATA
1	Mechanism	Solid NAND Flash	Magnetic rotating platters
2	Speed (SATA II)	80-250MB/sec	65-85MB/sec
3	Average Seek Time	0	< 10 ms
4	Noise	None	Noisy
5	Power Consumption	2W>, Low Power consumption	10W, Generate more heat
6	Weight	Lightweight	Heavier
7	Endurance	MTBF > 2.000, 000 Hours	MTBF < 700,000 Hours
8	Temperature	-40 ~ 85	0 ~ 60
9	Reliability	Anti-shock	Non-shock resistant
10	Shock & Vibration	Excellent	Poor

4. Useful-Life and Shelf-Life of NAND SSD

Flash is unlike other memory semiconductors because NAND flash has a finite useful life that wears-out over time as well as a limited “shelf-life” for holding data over long periods of inactivity. The term “flash endurance” is the useful life of the flash and the term “data retention” can be considered as the shelf-life of the flash. There are several methods used to extend the

longevity of SSD’s; the most important being the flash controller, not the flash, since endurance continues to drop as device capacities increase. The intelligence of the flash controller manages how often each flash memory cell is being used and maximizes the useful life of the SSD by “managing” the technical limitation of flash [7, 8] endurance and data retention both in speed and attributes seen in table 2, and table 3

Table 3. SSD Performance (Dataplex NAND SSD cyclic speed)

SN	NAND FLASH CHIP	CYCLIC SPEED
1	Data integrity	100, 000 erase cycles
2	Page Read	0,025 ms
3	Page Program time	0.2 ms
4	Block Erase	2 ms

Table 4 NAND Attributes and improvement over some years

SN	ATTRIBUTE	2017	2018	2019	2020	2021
1	Max die density	2GB	MLC 8GB	SLC 8GB MLC 16GB	SLC 16GB MLC 32GB	SLC 32GB MLC 64GB
2	Geometry trend	9X	7X	5X	3X	2X
3	Geometry (nm)	90	72	50	34	25
4	Page size (kb)	2112	2112	4314	4320	8640
5	Block size (kb)	128	MLC 256	SLC 256 MLC 512	SLC 512 MLC 1024	SLC 1024 MLC 2048
6	Interface	SDR 40	SDR 50	SDR 50	DDR 166	DDR 200
7	Temperature	Commercial 0-70c	Commercial 0-70c	Commercial 0-70c	Commercial 0-70c Industrial 45-85c	Commercial 0-70c Industrial 45-85c

5. Results of Hard Disk Drives

From the expression, we observed that at certain period of usage of components, the failure rate of such component will definitely occurred and that equipment will

have depreciated, this will also affect the performance of that system, a measure to arrest the situation is to replace such device or components

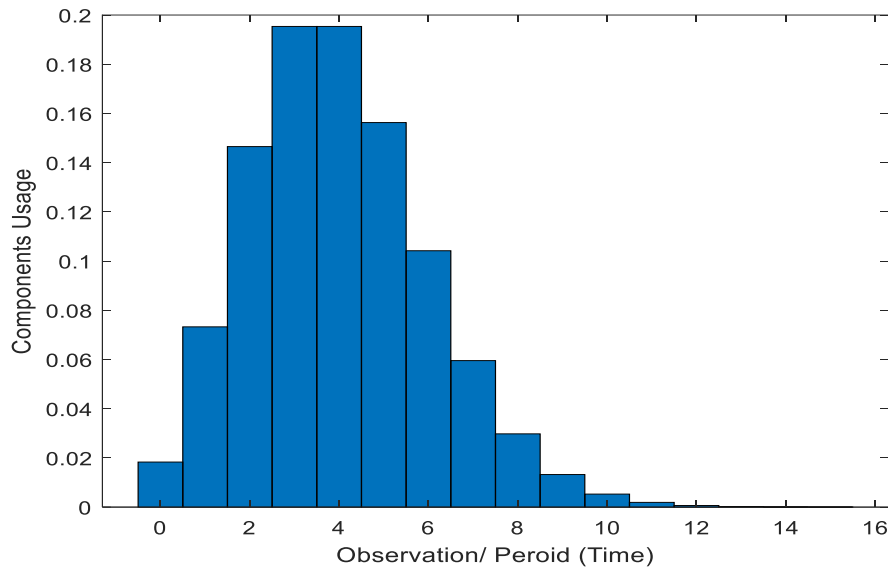

Figure 4: Behavioral characteristics of computer system drives

In Figure 4. the operational characteristics of computer system drives shows a rapid ascending order during the initial start of operations and gradually reaches its peak at some periods due to operating conditions that might be favorable or not. Further, after some period of operation it reaches the highest peak of approximately 2 and it starts

descending gradually, during those period of descending, some drives may totally failed which need an upgrade or replacement, while other continue to function until there get to a period in operation where there are no longer functional again, that is between 12.

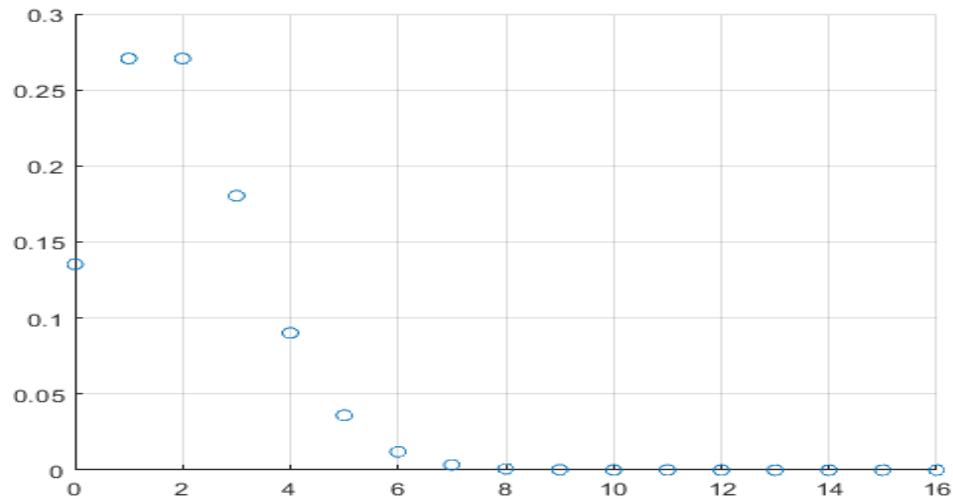

Figure 5: degradation pattern of installed computer drives

In Figure 5, the growth curve can be seen projected from somewhere above 0.1 which is the first Year in operation into the future by continuing. The resultant projection is an estimate of the installation's growth based on current applications and includes growth from additional applications implemented since the starting point and from changes in technology. In many installations, the applications that account for the bulk of system use are implemented very early; those added after the first year are used less.

Also, in Figure 5, although usage tripled over those years, showing stable operating conditions but it starts showing steady decline due to the additional usage over the next four years only equaled the first year's decline. This is a fairly typical growth pattern in which the new equipment (device) is justified early and decrease signs show gradually the system functionality over time which need an upgrade.

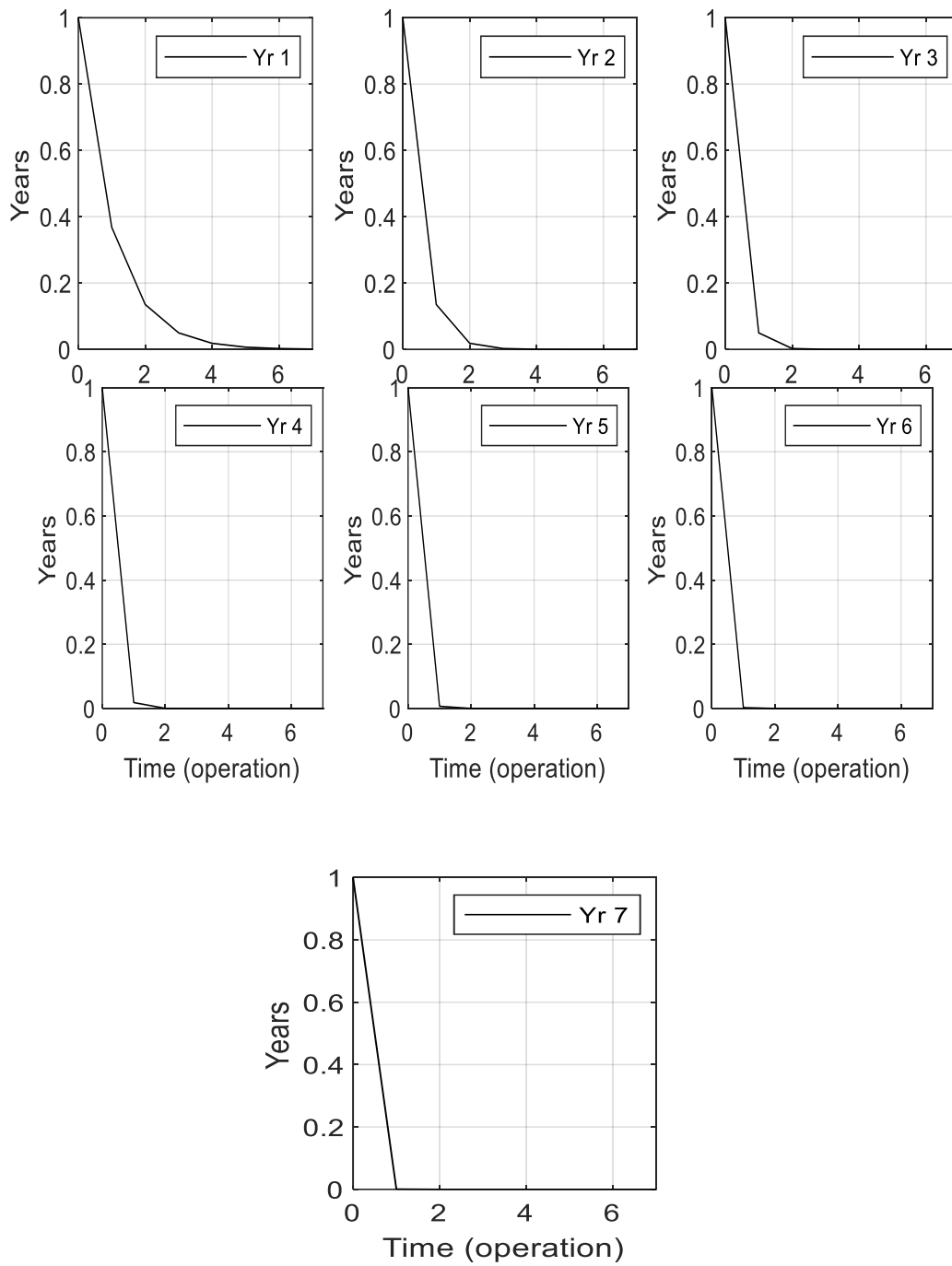

Figure 6 (a-g) components degradation over a seven-year observed period

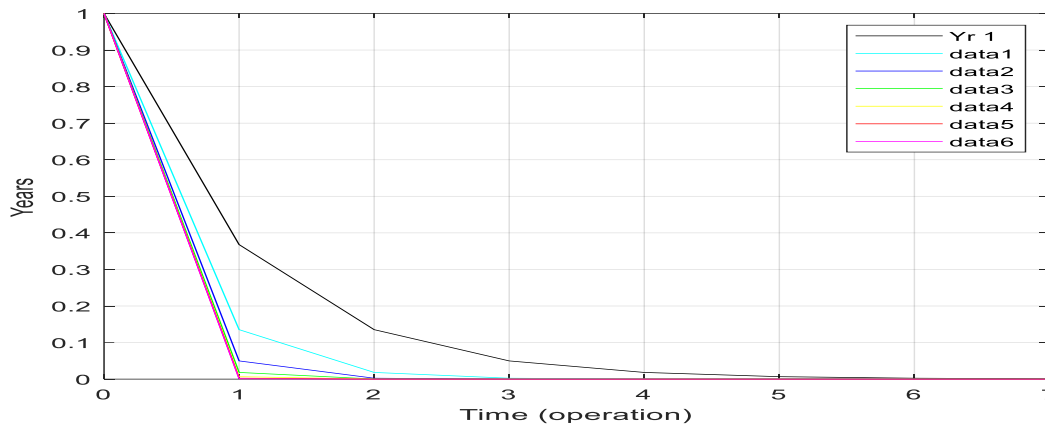

Figure 7: simplified degradation over drives a seven-year period

In Figure 5, which shows the operating condition over a seven-year period. System component operations sometimes predictions that can be made with confidence; for example, microprocessors with the power of an IBM 3081 system may some days failed and reduces it functionality below average. Unfortunately, if an organization is committed to the hardware or software of a different vendor, within a specified year, such component is obsolete. In figure 7, shows a simplified combination operation of system component devices over a period of seven years and their operating hours. The figure generally shows that component loses the capacity over time due to operating conditions and require frequent replacement to make up with organizational goals.

6. Conclusion

Sequel to critical evaluation and observations of the operation of the system storage component/ drives and their functions. Upgrading drives add values and improve performance of the overall system. From our analysis the operating capacity and functionality of storage drives decrease with time. The overall replacement of storage drives are rapid which is in line with perceived observations and research measurements over seven years which is found between average (53.3) We also observed that fifty-three percent of end-users are involved in rapid replacement of storage devices over the years.

Limitations of the SSD drives arises on forensic investigators need to come up with new methods to overcome the destructive capacity of the solid state drives

architecture. As researchers stated that solid state drives are becoming the current practice in digital forensic recovery and review the current techniques used in emerging new tools for cracking even the self-destructed files in Solid state drives. If

References:

- [1] S. A. Chamazcoti, B. Safaei, and S. G. Miremadi, "Can erasure codes damage reliability in SSD-based storage systems?" *IEEE Transactions on Emerging Topics in Computing*, vol. 7, no. 3, pp. 435-446, July 2019
- [2] C. Kim, D. Kim, W. Jeong, H. Kim, I. H. Park, H. Park, J. Lee, J. Park, Y. Ahn, J. Y. Lee, S. Kim, H. Yoon, J. D. Yu, N. Choi, N. Kim, H. Jang, J. Park, S. Song, Y. Park, J. Bang, S. Hong, Y. Choi, M. Kim, H. Kim, P. Kwak, J. Ihm, D. S. Byeon, J. Lee, K. Park, and K. Kyung, "A 512-gb 3-b/cell 64-stacked wl 3-d-nand flash memory," *IEEE Journal of Solid-State Circuits*, vol. 53, no. 1, pp.124-133, Jan 2018.
- [3] "HDDs and SSDs: global shipments 2015-2021." [Online]. Available: <https://www.statista.com/statistics/285474/hdds>
- [4] Wei, Michael, Laura Grupp, Steven Swanson. "Reliably Erasing Data from Flash-Based Solid State Drives." University of California, San Diego 2020
- [5] Spierings, A., Kerr, D. & Houghton, L. Issues that support the creation of ICT workarounds: towards a theoretical understanding of feral information systems. *Inf Syst J.* 27(6):775–94. doi:10.1111/ isj.12123. 2017
- [6] Zhang Baihui. . Research on Computer Software and Hardware Resource Sharing under the Application of Network Technology. *Modern Information Technology*, vol. 3, no. 4, pp. 94-96. 2019.
- [7] Du Nan. (2020). Computer software and hardware resource sharing technology under the application of network technology. *Information Technology and Information Technology* 242, no. 5, pp. 175-177.
- [8] Abhinav Sekhri, (2020) Admission24 https://www.admission24.com/school-management?gclid=Cj0KCQjwwr32BRD4ARIsAAJNf_

- 0MeQ808_8kEORNpUzdw12APKa2
Dc6bF7FiYXk4h-
Z4bUs9rLN5H6MaAjR9EALw_wc
- [9] Rajivan, Prashanth; Aharonov-Majar, Efrat; Gonzalez, Cleotilde. Update now or later? Effects of experience, cost, and risk preference on update decisions. *Journal of Cybersecurity*, 6(1), tyaa002-. doi:10.1093/cybsec/tyaa002, 2020.
- [10] Brent Furneaux, Sophia Mannina & Lars Rieser. Responding to Information System Obsolescence: Should We Upgrade or Replace? *Journal of Computer Information Systems*, 62:2, 372-383, DOI: 10.1080/08874417.2020.1830006 2022.
- [11] Akusa Peter Aker., "COMPUTER HARDWARE REPAIRS AND MAINTENANCE". At the Workshop for Information and Communication Technology Staff organized by the National Judicial Institute, 2017.
- [12] C. Park et al., "A High Performance Controller for NAND Flash-based Solid State Disk (NSSD)", *IEEE Non-Volatile Semiconductor Memory Workshop NVSMW*, pp. 17–20, 2022